

# JOHNSON ELECTRIC ENGINEERING LTD.

Project No : Production Motor  
Curve No : KC615L-65320

Winding : 0.55 - 18

Date : 04/27/1999  
Model :

Full Scales : 50.00 Amp  
200.00 Watts

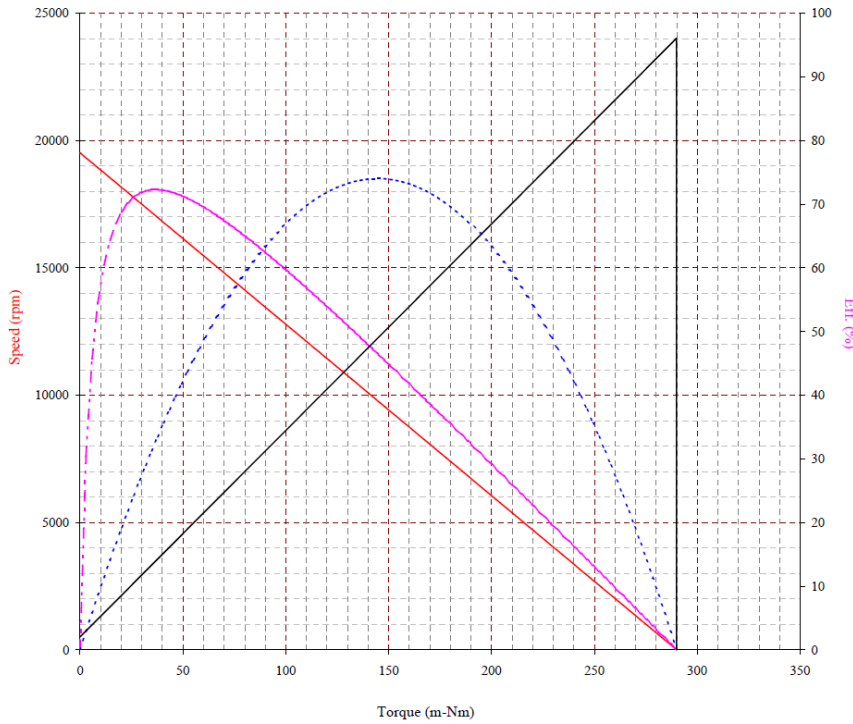

Motor tested rapidly to prevent significant temperature rise.

At a constant voltage of **13.00** Volts  
with a circuit resistance **0.000** Ohm

(At the ambient temperature of 25-30 deg C)

At No Load

Speed : 19517 Rpm  
Current : 1.013 Amp

At Stall (Extrapolated)

Torque : 289.91 m-Nm  
Current : 48.04 Amp

At Maximum Efficiency

Efficiency : 72.29 %  
Torque : 37.69 m-Nm  
Speed : 16980 Rpm  
Current : 7.13 Amp  
Output : 66.98 Watts

At Maximum Power

Torque : 144.96 m-Nm  
Speed : 9759 Rpm  
Current : 24.53 Amp  
Output : 148.03 Watts

Characteristics

Torque Constant : 6.1650 m-Nm/Amp  
Dy. Resistance : 0.2710 Ohms  
Motor Regulation : 67.3210 Rpm/m-Nm

COMPUTER PRINT-OUT  
NOMINAL MOTOR CURVES.  
Performance and characteristics are measured based on limited motor samples only.

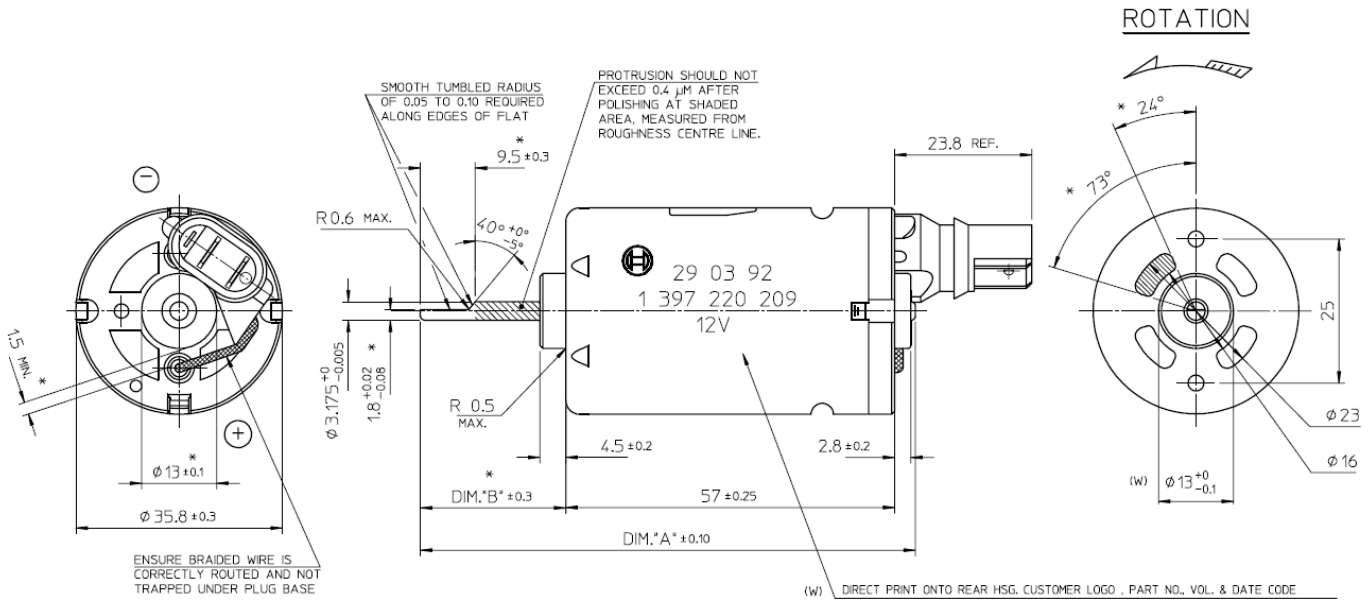

NOTES:-

1. LENGTH OF SHAFT, DIM. \*A\* 85.80 mm..
2. FRONT EXTENSION, DIM. \*B\* 25.20 mm., MEASURED WITH A FORCE OF 510 gms. (5N) PUSHING SHAFT AGAINST PLASTIC END CAP.
3. DIRECTION OF ROTATION : ANTI-CLOCKWISE WHEN VIEWING MOTOR OUTPUT END WITH POSITIVE VOLTAGE APPLIED TO POSITIVE TERMINAL.
4. END PLAY : 0.50 mm. MAX..
5. THE ASSEMBLED PLUG IS TO WITHSTAND A PULL OFF FORCE OF 250 gms.
6. THE DIMS. MARKED \* THUS SPECIAL CUSTOMER REQUIREMENTS.